

GENERAL NOTES

1. ALL MEASUREMENTS IN METRES UNLESS OTHERWISE NOTED.
2. ALL EXISTING FEATURES AND UTILITIES ARE TO BE VERIFIED PRIOR TO CONSTRUCTION.
3. INFORM THE PROJECT LANDSCAPE ARCHITECT OF ANY DISCREPANCIES BETWEEN PLAN DETAILS AND IN-FIELD MEASUREMENTS. COMPLETION OF UNAUTHORIZED CHANGES MAY BE SUBJECT TO REJECTION.
4. CONTRACTOR TO MAKE GOOD ALL CONSTRUCTION RELATED DAMAGE OUTSIDE THE LIMIT OF WORK.
5. DESIGNS, PLANS AND RECOMMENDATIONS ARE PROVIDED FOR THE SPECIFIC PURPOSE INDICATED HEREIN AND MAY NEED TO BE MODIFIED DEPENDING ON ACTUAL FIELD CONDITIONS THAT MAY BE DISCOVERED DURING CONSTRUCTION. LANARC 2015 CONSULTANTS LTD. EXPRESSLY DENIES ANY RESPONSIBILITY FOR CONSTRUCTED WORKS THAT ARE SUBJECT TO SITE CONDITIONS THAT AFFECT THE INTEGRITY OF THE DESIGN.
6. THIS DRAWING SET AND THIS DESIGN ARE THE PROPERTY OF LANARC 2015 CONSULTANTS LTD. (LANARC) AND SHALL NOT BE USED, REUSED OR REPRODUCED WITHOUT THE CONSENT OF LANARC. LANARC WILL NOT BE HELD RESPONSIBLE FOR THE IMPROPER OR UNAUTHORIZED USE OF THIS DRAWING SET AND DESIGN, OR ANY CHANGES MADE TO THE DRAWINGS BY ANY THIRD PARTY, INCLUDING CONTRACTORS, SUPPLIERS, CONSULTANTS, AND STAKEHOLDERS, OR THEIR EMPLOYEES OR AGENTS, WITHOUT LANARC'S PRIOR WRITTEN CONSENT.
7. LANARC HAS PREPARED THESE DRAWINGS IN A MANNER CONSISTENT WITH THAT LEVEL OF CARE AND SKILL ORDINARILY EXERCISED BY MEMBERS OF THE LANDSCAPE ARCHITECTURE PROFESSION CURRENTLY PRACTICING UNDER SIMILAR CONDITIONS IN THE JURISDICTION IN WHICH THE SERVICES ARE PROVIDED, SUBJECT TO THE TIME LIMITS AND PHYSICAL CONSTRAINTS APPLICABLE TO THE PROJECT.



1 CONTEXT PLAN
SCALE: 1:500

LANARC

405 - 256 Wallace Street, Nanaimo, BC V9R 5B3
Tel (778) 762-4800
www.lanarcconsultants.ca



830 Cliffe Avenue, Courtenay, BC V9N 2J7
Tel (250) 334-4441
www.courtenay.ca

PRELIMINARY
NOT FOR CONSTRUCTION

Schematic Design GL JG 2025.12.10

Issued By Appd. YY.MM.DD

Permit-Seal

**Lewis Park
Pickleball Courts**

Project

Context Plan

Title



25624 0 1:500 25
Project No. Scale

L0.0 A
Drawing No. Permit No. Revision





NOTES

1. REFER TO GENERAL NOTES ON L0.0.
2. EXISTING HORSESHOE PITS AND SHELTERS TO BE REMOVED.
3. EXISTING CHAIN LINK FENCE TO BE REMOVED.

PAVING/SURFACING SCHEDULE

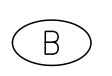
SYMBOL	ITEM	FINISH/COLOUR/NOTES	DETAIL
	PAVING TYPE 1	ASPHALT	6 / L2.0
	PAVING TYPE 2	ASPHALT WITH NON-SLIP, WEATHER-RESISTANT ACRYLIC COATING	6 / L2.0

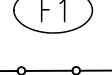
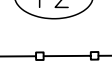
SITE FURNISHINGS SCHEDULE

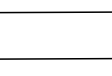
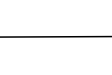
SYMBOL	ITEM	DESCRIPTION/NOTES	DETAIL
	BENCH	WISHBONE BAYVIEW BENCH, REDWOOD RECYCLED PLASTIC LUMBER, BLACK POWDERCOAT FINISH	5 / L2.0
	BIKE RACK	URBAN RACKS URBAN STAPLE BIKE RACK, BLACK POWDERCOAT FINISH	7 / L2.0
	FENCE TYPE 1	4' CHAIN LINK FENCE WITH RAIL GUARD	1 / L2.0
	FENCE TYPE 2	10' CHAIN LINK FENCE	2 / L2.0
	GATE	CHAIN LINK GATE WITH PIN LATCH	2 / L2.0
	PICKLEBALL NET	21'9" x 36" PICKLEBALL NET	4 / L2.0
	PICKLEBALL POST	GALVANIZED PIPE WITH WELDED PIPE CAP, BLACK POWDERCOAT FINISH	3 / L2.0

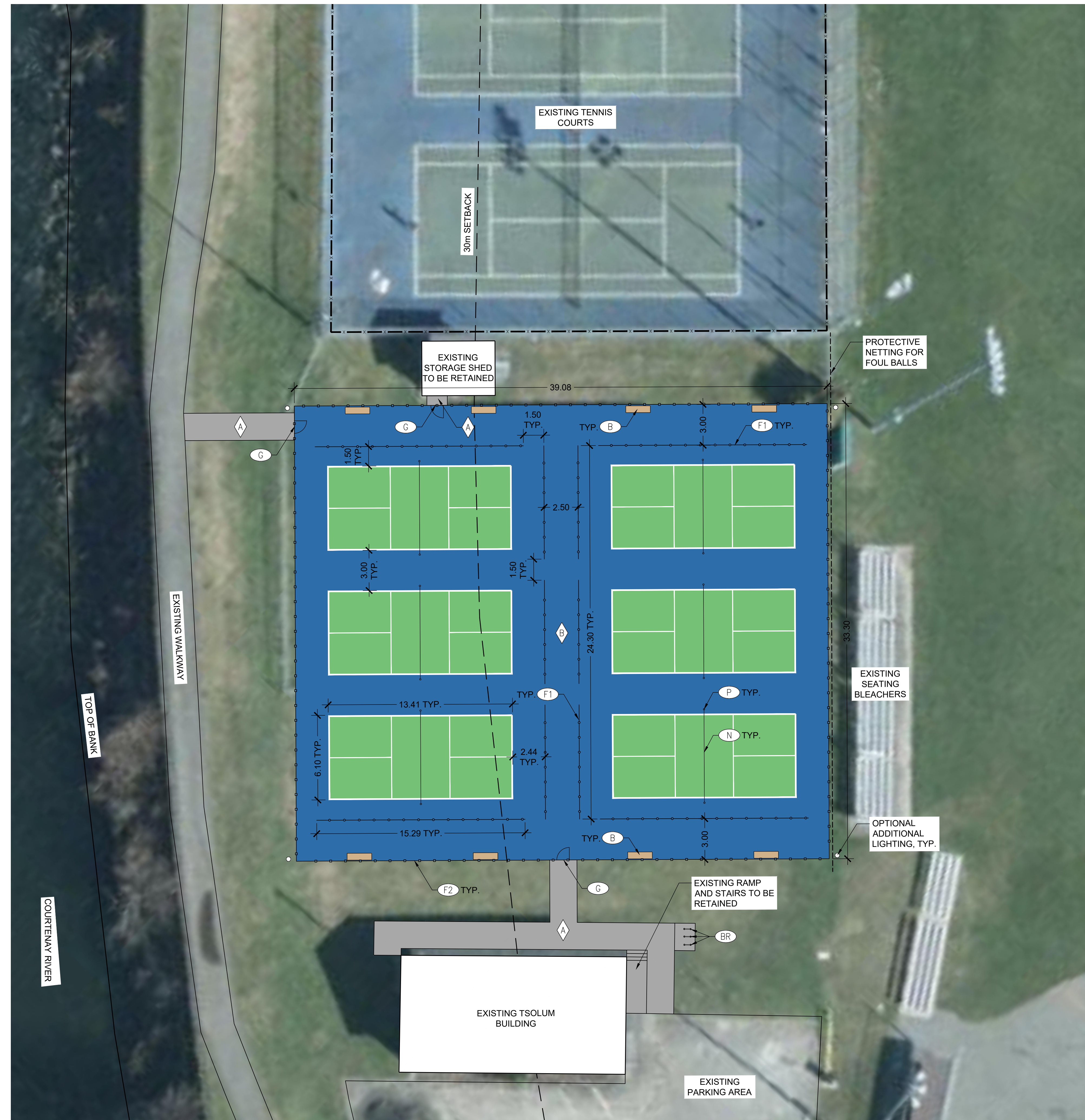

1 MATERIALS PLAN
SCALE: 1:150

LANARC

405 - 256 Wallace Street, Nanaimo, BC V9R 5B3
Tel (778) 762-4800
www.lanarcconsultants.ca



830 Cliffe Avenue, Courtenay, BC V9N 2J7
Tel (250) 334-4441
www.courtenay.ca

PRELIMINARY
NOT FOR CONSTRUCTION

Schematic Design GL JG 2025.12.10

Issued By Appd. YY.MM.DD

Permit-Seal

**Lewis Park
Pickleball Courts**

Project

Materials Plan

Title

25624 0 1:150 5

Project No. Scale

L1.0 A

Drawing No. Permit No. Revision

NOTES:

- 4' HIGH FENCE IS POWDER COATED BLACK
- FENCE TO BE WELDED AND WELDS ARE TO BE PAINTED IN ZINC RICH PRIMER
- CONCRETE FOOTING AS PER STAMPED ENGINEERING DRAWINGS
- ALL POST FOOTINGS TO BE AUGURED A MINIMUM 915mm INTO NATURAL FIRM BEARING

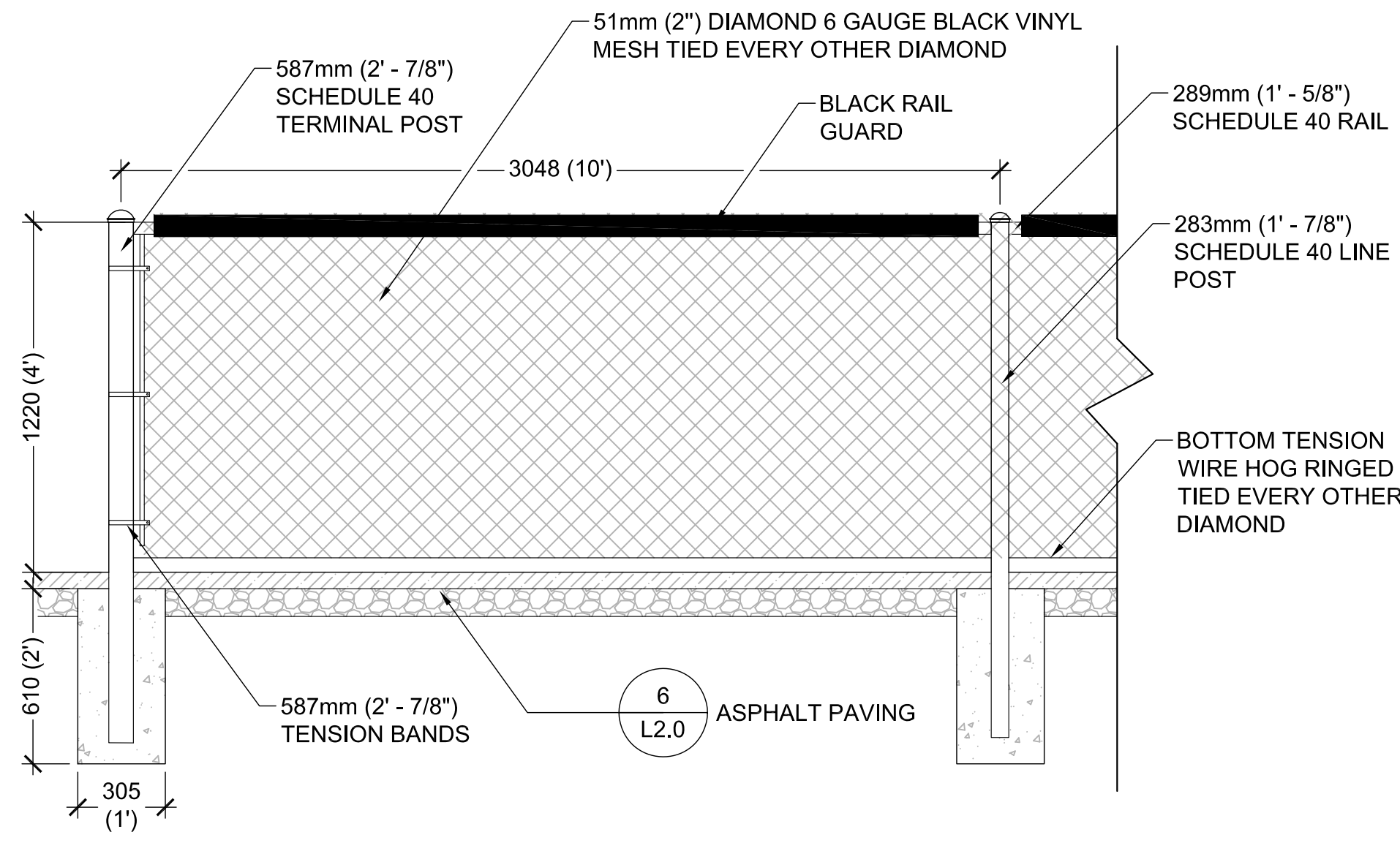

1 TYPICAL 4' FENCE ELEVATION

SCALE: 1:20

NOTES:

- ENTIRE POST SURFACE TO RECEIVE BLACK POWDERCOAT FINISH

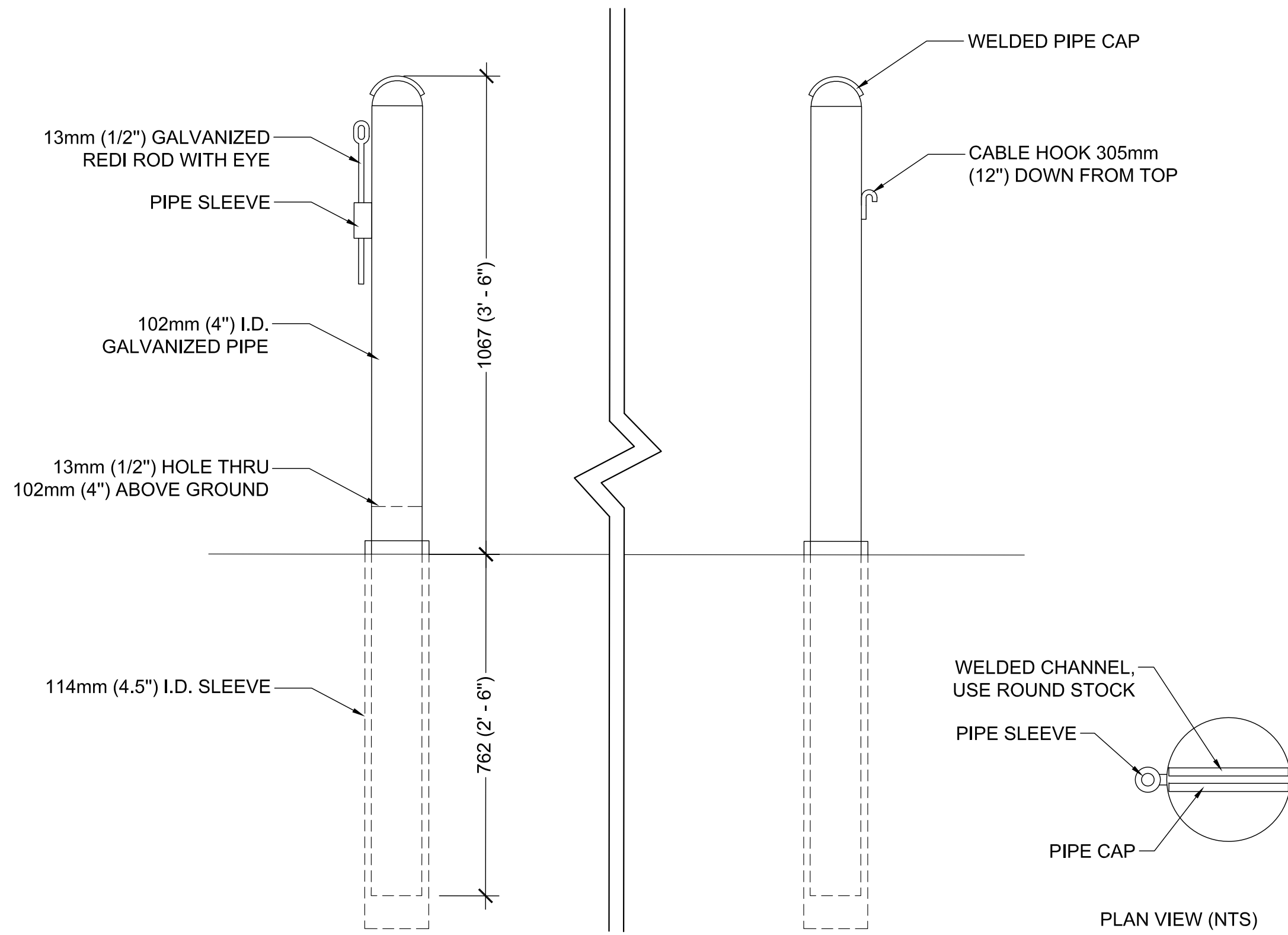

3 PICKLEBALL POSTS

SCALE: 1:10

NOTES:

- 10' FENCE TO BE GALVANIZED MATERIAL WITH BLACK POWDERCOAT FINISH
- FENCE TO BE WELDED AND WELDS ARE TO BE PAINTED IN ZINC RICH PRIMER
- CONCRETE FOOTING AS PER STAMPED ENGINEERING DRAWINGS
- ALL POST FOOTINGS TO BE AUGURED A MINIMUM 915mm INTO NATURAL FIRM BEARING

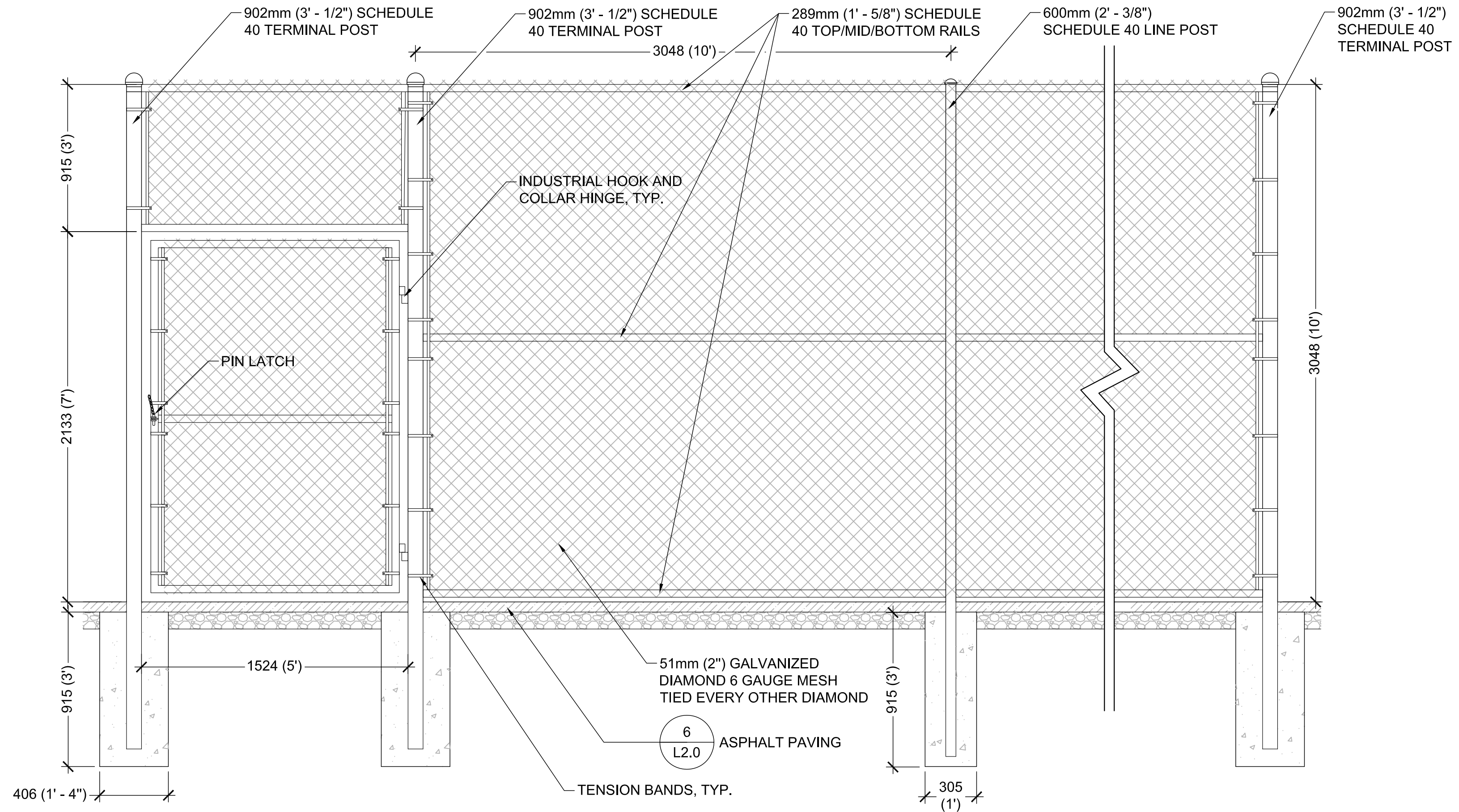

2 TYPICAL 10' FENCE ELEVATION

SCALE: 1:20



NOTES:

- PREPARATION, SUPPLY, AND INSTALLATION ALL TO BE PROVIDED BY CONTRACTOR.
- INSTALL PER MANUFACTURERS RECOMMENDATIONS.
- NET MANUFACTURER: DIY COURT CANADA (www.diycourt.ca)
- NET MODEL & INFO
 - DOUGLAS PICKLEBALL NET (JTN-30)
 - 21'9" x 36"
 - 1-3/4" SQUARE MESH
 - BRAIDED 3mm POLYETHYLENE

4 PICKLEBALL NET

SCALE: NTS

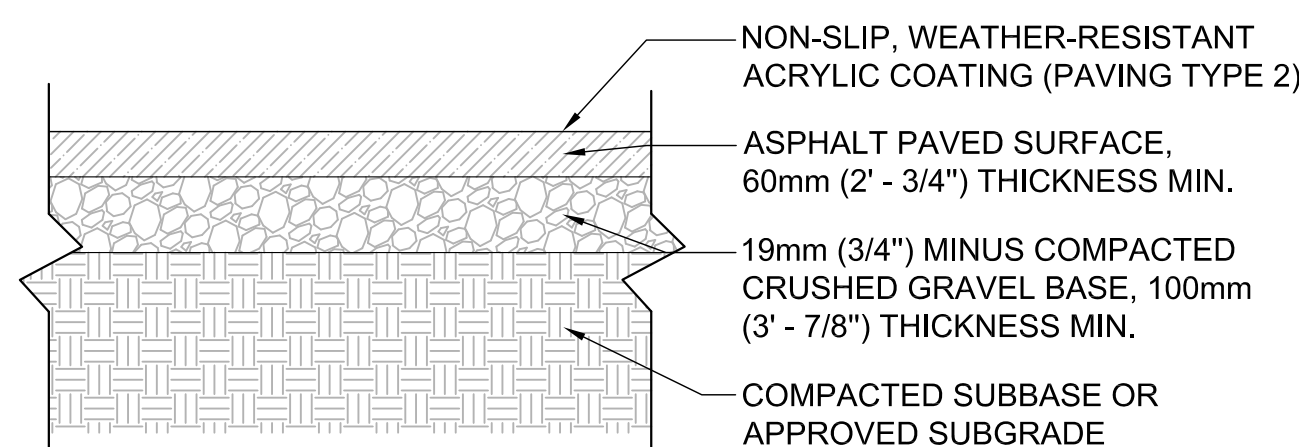

6 ASPHALT PAVING

SCALE: 1:10



NOTES:

- PREPARATION, SUPPLY, AND INSTALLATION ALL TO BE PROVIDED BY CONTRACTOR.
- SURFACE MOUNT PER MANUFACTURERS RECOMMENDATIONS.
- BENCH MANUFACTURER: WISHBONE SITE FURNISHINGS (www.wishboneltd.com)
- BENCH MODEL & INFO
 - BAYVIEW PARK BENCH
 - 6' WIDE WOOD
 - BLACK POWDERCOAT STEEL FRAME
 - REDWOOD RECYCLED PLASTIC LUMBER

5 FREE STANDING BENCH

SCALE: NTS

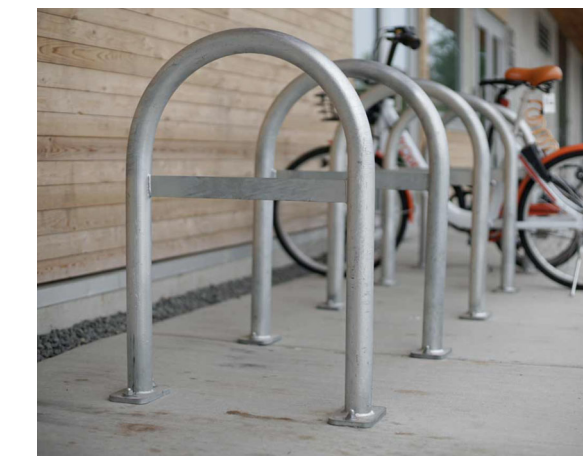

NOTES:

- PREPARATION, SUPPLY, AND INSTALLATION ALL TO BE PROVIDED BY CONTRACTOR.
- SURFACE MOUNT PER MANUFACTURERS RECOMMENDATIONS WITH TAMPERPROOF BOLTS.
- BIKE RACK MANUFACTURER: URBAN RACKS (www.urbanracks.com)
- BIKE RACK MODEL & INFO:
 - URABN STAPLE BIKE RACK
 - STAINLESS STEEL TUBE
 - BLACK POWDERCOAT FINISH

7 BIKE RACK

SCALE: NTS

LANARC

405 - 256 Wallace Street, Nanaimo, BC V9R 5B3
Tel (778) 762-4800
www.lanarcconsultants.ca



830 Cliffe Avenue, Courtenay, BC V9N 2J7
Tel (250) 334-4441
www.courtenay.ca

PRELIMINARY
NOT FOR CONSTRUCTION

Schematic Design GL JG 2025.12.10

Issued By Appd. YY.MM.DD

Permit-Seal

**Lewis Park
Pickleball Courts**

Project

Landscape Details

Title

25624

Project No. Scale

L2.0

Drawing No. Permit No. Revision **A**

City of Courtenay
Pickleball Options Analysis
Lewis Park Schematic Design

DATE: December 10, 2025

CLASS 'D' OPINION OF PROBABLE COST

Lanarc

ITEM	UNIT	QUANTITY	UNIT-COST	TOTALS
GENERAL				
Mobilization and Demobilization	Lump Sum	1	\$5,000	\$5,000
Removal & Disposal of Existing Horseshoe Pits & Structures	Lump Sum	1	\$10,000	\$10,000
Subgrade Preparation, Excavation, Existing Materials Removal	Lump Sum	1	\$30,000	\$30,000
Granular Base, Rough Grading	Lump Sum	1	\$20,000	\$20,000
Subtotal				\$ 65,000
HARD LANDSCAPE (Supply and Install)				
Asphalt Paving (Court)	sq.m.	1185	\$100	\$118,500
Asphalt Paving (Pathway)	sq.m.	85	\$100	\$8,500
Court Painting	allowance	-	\$60,000	\$60,000
Subtotal				\$ 187,000
FURNISHINGS (Supply and Install)				
Benches	each	8	\$2,500	\$20,000
Bike Racks	each	3	\$1,500	\$4,500
Chain-link Fence (10' Height Exterior & 4' Height b/w Courts; incl. gates)	allowance	-	\$150,000	\$150,000
Foul Ball Protective Netting	allowance	-	\$60,000	\$60,000
Pickleball Posts	each	12	\$2,000	\$24,000
Pickleball Nets	each	6	\$1,000	\$6,000
AED	each	1	\$3,500	\$3,500
Subtotal				\$ 268,000
SOFT COSTS				
Permitting (Archaeology Assessment, KFN Consultation, Environmental Assessment; Allowance)				\$ 35,000
Consulting Fees (10% of Construction Cost)				\$ 52,000
Subtotal				\$ 607,000
Class 'D' 40% Contingency				\$ 242,800
Total Project Estimate (incl. contingency)				\$ 849,800

Notes:

Prices listed are 'supply and install' figures.

Estimated year of construction to be 2027.

Contingency applied at early design stages to account for unknowns (such as unexpected subgrade conditions, etc.).

This cost estimate is based on past project experience. Actual costs can differ widely depending on industry labour and material availability.

Lanarc 2015 Consultants Ltd. accepts no liability for actual cost which may vary from the estimated costs provided herein.

Recommendations from Civil Engineer required for detailed costing related to site services, parking, and/or infrastructure.

Recommendations from Electrical Engineer required for detailed costing related to electrical site services, power, or lighting.

Prices for permitting costs and consultant fees are estimates only.